

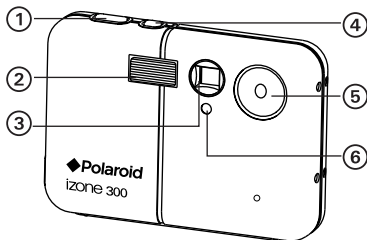

.....  
**iPhone 300™ Digital Camera  
User Guide**

## Product Overview

1. Shutter button
2. Flash
3. Viewfinder
4. Power button
5. Lens
6. Self Timer LED



1. Viewfinder
2. Saving LED
3. LCD screen
4. Menu / Left button
5. Down button
6. Flash / Battery charge LED
7. Capture / Playback mode button
8. LCD screen on/off button
9. Up button
10. Set / Right button
11. Reset button

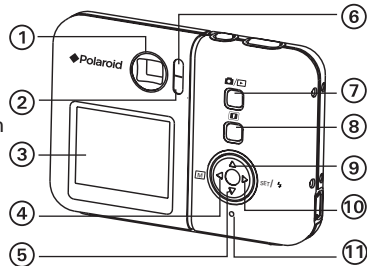

1. USB port
2. SD card slot

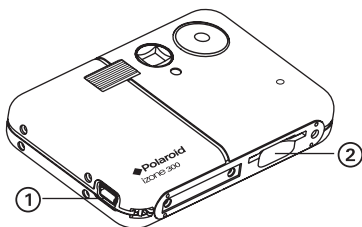

- 
1. USB port
  2. USB plug

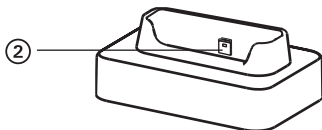
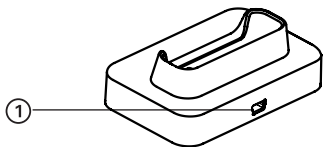

Docking Station

## Table of Contents

1 Getting Started .....	7
• Camera Package Contents.....	8
• Attaching the Hand Strap.....	9
• Using the Docking Station.....	9
• How to Use the Tether (Optional).....	10
• Charging the Battery.....	11
• Turning the Camera On and Off .....	15
• Reset Feature.....	16
• Checking the Battery Power Level.....	16
• How to Navigate Menus.....	17
2 Camera Setting .....	18
• Checking Camera Status .....	18
• Camera Modes .....	20
• Drive Mode .....	20
• Setup Menu .....	20
• Formatting the Internal Memory.....	22
• Setting the Current Date and Time.....	23
• Auto Power Save Setting .....	24
• Setting the Beep Sound On/Off .....	25
• Setting Frequency .....	25
• Setting Display Language.....	26
• Setting the Date Stamp On and Off.....	27
• Resetting to Default Settings.....	27
• Switching the Information Display and LCD Screen On and Off.....	28

3 Taking Pictures.....	29
• Taking a Picture.....	29
• Taking a Picture with the LCD Screen Off .....	29
• Setting Flash Mode.....	30
• Setting Self-timer .....	32
• Zoom Feature.....	33
• Setting the Image Size and Quality .....	34
• Setting Exposure Compensation .....	36
• Setting the White Balance for Pictures .....	37
4 Recording Video Clips .....	38
• Recording Video Clips.....	38
• Setting Video Resolution.....	39
• Setting the White Balance for Video Clips.....	40
5 Reviewing and Managing Pictures and Video Clips.....	41
• Reviewing the Pictures.....	41
• Reviewing Picture and Video Clip Files in Thumbnail .....	41
• Auto Play.....	42
• Playing the Video Clip .....	44
• Protect or Unprotect Picture(s) or Video Clip(s).....	44
• Deleting Picture(s) or Video Clip(s) .....	45
6 Print Settings .....	46
• About PictBridge .....	46
• DPOF (Digital Print Order Format) .....	53
7 Using SD (Secure Digital) Card .....	56
• Using the SD Card .....	56
• To Copy Pictures and Video Clips from Internal Memory to a Memory Card.....	59
8 Installing the Software onto a Computer.....	60
• Installing the Software.....	60
• Software Included with Your Camera .....	62
• Computer System Requirements .....	64

9	Transferring Pictures and Video Clips To Your Computer .....	65
	• Before You Transfer Files.....	65
	• Changing the Driver Type Between Mass Storage Mode and PC Camera Mode.....	65
	• Connecting to Your Computer.....	66
	• Transferring Pictures and Video Clips .....	67
10	Using the Camera as a Web Cam (PC Only).....	68
	• Setting up NetMeeting™ .....	68
	• Start NetMeeting™ .....	69
11	Troubleshooting Problems.....	72
12	Getting Help.....	73
	• Polaroid Online Services.....	73
	• Customer Support .....	73
	• ArcSoft Software Help.....	73
13	Appendix .....	74
	• Technical Specifications.....	74
	• Storage Capacities .....	76
	• Uninstalling Polaroid ize300™ driver (PC Only) .....	79
	• Camera Default Settings .....	80
	• Using Your Battery .....	81
	• Tips, Your Safety & Maintenance.....	81
	• Regulatory Information .....	82

## 1 Getting Started

The izone300™ camera has easy-to-use features. It has never been easier or more enjoyable to take digital pictures. Here are a few examples of what you can do with your camera.

- Enjoy point & shoot operation. Adjust the resolution for print or email.
- Store pictures and video clips to the internal memory or a SD card.
- Playback of pictures and video clips on the LCD screen or on a computer.
- Send the pictures and video clips over the Internet to family and friends.
- Enjoy PictBridge directly plug-and-print experience.

## • Camera Package Contents



izeone300™



Registration Card

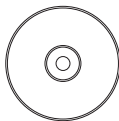

The CD-ROM includes  
Polaroid izone300™ Camera driver (PC)  
izeone PhotoBase (PC & Mac)  
Microsoft® NetMeeting™ (PC)  
Adobe® Acrobat® Reader™ (PC & Mac)  
User Guide (in PDF format)



USB Cable



Quick Guide



Docking Station



Pouch



Hand Strap



AC Adapter  
(Optional)



USB Connector  
(Optional)



Tether  
(Optional)



- **Attaching the Hand Strap**

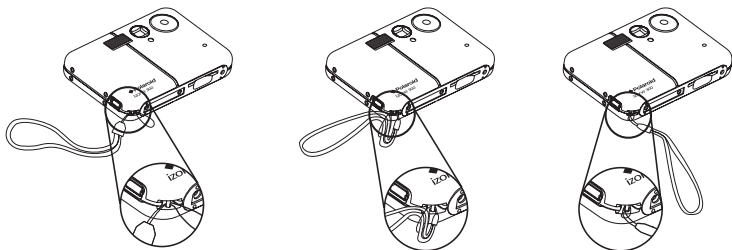

- **Using the Docking Station**

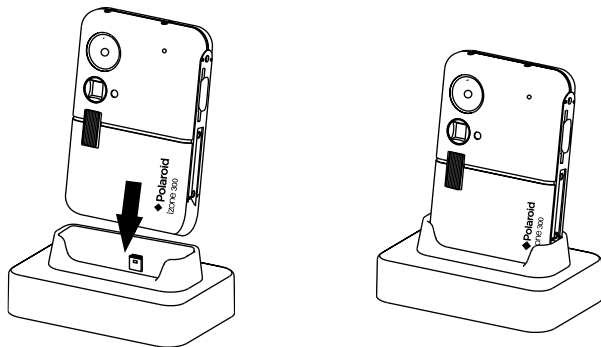

## • How to Use the Tether (Optional)

A rubber tether is included in the accessory kit of the camera. It offers a quick, simple, and secure connection between the USB connector and the AC adapter for battery charge.



AC Adapter (Optional)



Tether (Optional)



USB Connector (Optional)

### Connecting USB Connector with AC Adapter

1. Put the jack of USB connector through one ring of the tether.
2. Put the plug of AC adapter through the other ring of the tether.
3. Connect the AC adapter with the USB connector.

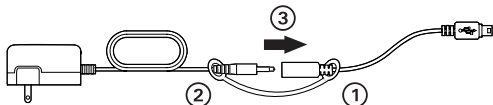

Electric current varies for different computers. Some computers may not provide a sufficient charging current. For a full battery charge or when you use the camera away from your computer, we recommend the usage of an AC adapter (DC 5V, 500 mA, with a 3.5 x 1.35 x 9 mm female plug, Positive Center) to charge the battery.

Visit [www.polaroid.com](http://www.polaroid.com) for detailed information on an adapter.

## • Charging the Battery



There are four ways to charge the battery. Please fully charge the battery for four hours before using the camera for the first time after purchase, and about three hours for subsequent recharging.



### NOTE:

- It is normal for the camera to be slightly warm while charging the battery.
- Electric current varies for different computers. Some computers may not provide a sufficient charging current. For a full battery charge or when you use the camera away from your computer, we recommend the usage of an AC adapter (DC 5V, 500 mA, with a 3.5 x 1.35 x 9 mm female plug, Positive Center) to charge the battery.  
Visit [www.polaroid.com](http://www.polaroid.com) for detailed information on an adapter.
- For a full battery charge, we recommend turning off the camera before charging the battery.
- To get the best performance out of the battery, it is recommended the camera be kept charged at all times. Especially when not in use for a period of time, like over a month or so.
- When the camera is connected to a computer, a message may prompt for installing the camera driver. (The message window varies for different Windows® OS) The battery can be charged without installing the driver. Click "Cancel" to close the message window. To install the driver, please refer to page 60 "Installing the Software onto a Computer" for further details.



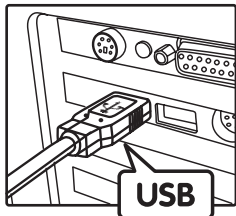

1. Using the USB cable via the computer
  - Plug the labelled end  of the USB cable into the socket marked  on your computer.
  - Plug the other end of the USB cable into the USB port on the camera. The battery begins charging and the battery charge LED on the camera blinks. The LED stops blinking and remains on when battery is fully charged.

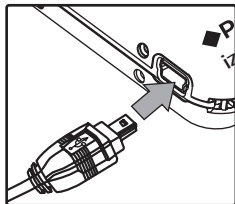

USB Series "A" Plug connects to your PC



USB Series "Mini B" Plug connects to your izone300™ Camera or Docking Station

2. Using the USB cable via the docking station.
- Place the camera into the docking station. For further details, refer to “Using the Docking Station” on page 9.
  - Plug the labelled end  of the USB cable into the socket marked  on your computer.
  - Plug the other end of the USB cable into the USB port on the docking station.  
The battery begins charging and the battery charge LED on the camera blinks. The LED stops blinking and remains on when battery is fully charged.

3. Using an AC adapter

If your camera comes with the USB connector and the tether, follow method A for battery charging.

A. Using an AC adapter and a USB Connector, via the camera (optional)

- Plug the labelled end  of the connector into the USB port on the camera.
- Connect the AC adapter with the USB connector.
- Connect the adapter to the household power outlet.  
The battery begins charging and the battery charge LED on the camera blinks. The LED stops blinking and remains on when battery is fully charged.

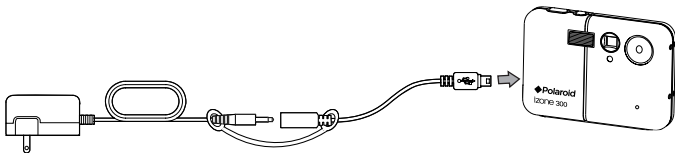

If your camera comes with an AC adapter like the diagram below, use method B for battery charging.

B. Using an AC adapter, via the camera (optional)

- Plug the labelled end  of the AC adapter into the USB port on the camera.
- Connect the adapter to the household power outlet.  
The battery begins charging and the battery charge LED on the camera blinks. The LED stops blinking and remains on when battery is fully charged.

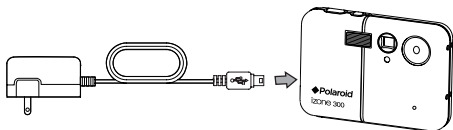

The internal battery should last for the life of the camera, but as is the case with all rechargeable batteries the actual charge held may decline with use. Should it ever become necessary to replace the internal battery, please visit [www.polaroid.com](http://www.polaroid.com) for service instructions.

### • Turning the Camera On and Off

To turn on the camera, fully press and hold the Power button until the LCD Screen is activated. Press and hold the Power button again and the camera will power off.

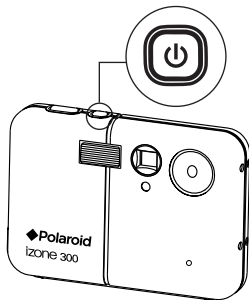

#### NOTE:

- Make sure that the Flash / Battery charge LED remains lighted before shooting.
- The camera is designed with an automatic power-off feature to conserve battery life. After a specified period of inactivity, the camera automatically powers off. Pressing the Power button can deactivate this feature and turn on the camera again.
- An indicator appears if battery power is low. Recharge the battery immediately.

## • Reset Feature

In the rare situation that the camera locks up (usually in a very low power situation), we have incorporated a Reset button on the back of the camera that allows the camera processor to be reset without losing any images.

To use the Reset button, simply depress the Reset button gently (holding for around 5 seconds) using a paper clip or ball point pen. The camera will power off automatically. It is important to note that the camera probably needs to be recharged immediately in order to avoid locking up again.

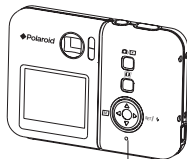

Reset Button

## • Checking the Battery Power Level

Check the battery power level before taking pictures.

1. Turn the camera on.
2. Check the battery power level that appears on the LCD screen.

- Battery power is full.
- Battery power is adequate.
- Battery power is low.
- Battery power is exhausted.

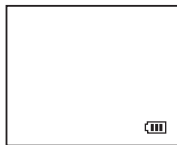



## • How to Navigate Menus

Menus are used to adjust capture and play settings, as well as other camera settings like the date/time and auto power off.

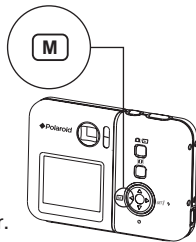

1. Press the **M** ◀ button to enter the menu bar. Press it again to exit.
2. Press the ▲ or ▼ button to select a menu item. Press the ▶ SET button to enter the submenu.

Press the **M** ◀ button to return to the menu

3. Press the ▲ or ▼ button to select the desired setting.
4. Press the ▶ SET button to confirm.

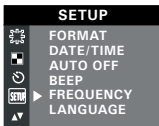
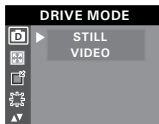

## 2 Camera Setting

### • Checking Camera Status

Turn on the camera, view the camera LCD screen to check which camera settings are active. Those particular features whose icons are not displayed are not activated.

### Still Image mode

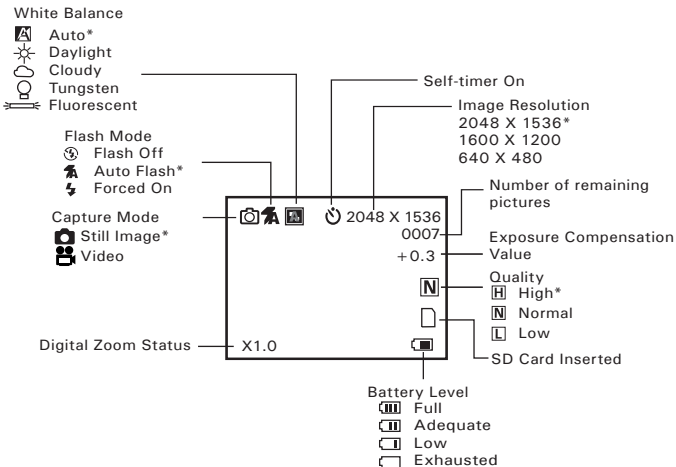

\* Default Setting

## Video mode

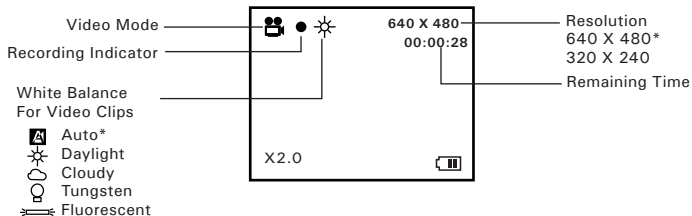

\* Default Setting

## Playback Mode

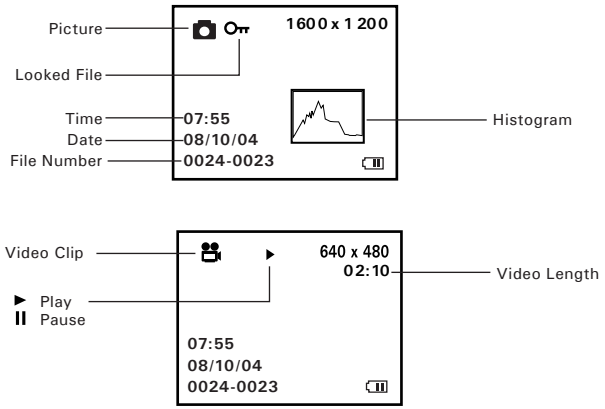

## • Camera Modes

The camera has two working modes, Capture mode and Playback mode. You can switch between them by pressing the Capture/Playback mode button at the back of the camera.

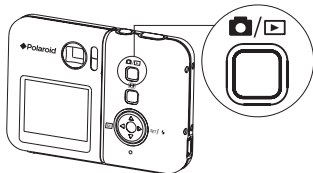

### **Capture Mode**

Under this mode, you can select the image and video settings according to shooting preference, and take pictures and video clips under the settings you have selected. For more details, please refer to “Taking Pictures” on page 29 and “Recording Video Clips” on page 38.

### **Playback Mode**

This mode allows the review or deletion of pictures and video clips from the camera. For more details, please refer to “Reviewing and Managing Pictures and Video Clips” on page 41.



## • Drive Mode

The camera has two modes for taking pictures and video clips.

 Still Image Mode

 Video Mode

You may switch between these two modes according to the following steps.

1. Set the camera to Capture mode .
2. Press the  ◀ button.
3. Press the ▲ or ▼ button to select  (DRIVE MODE).

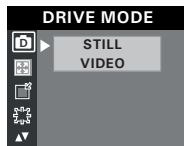



4. Press the ► SET button.
5. Press the ▲ or ▼ button to select the desired drive mode.
6. Press the ► SET button.

### NOTE:

- Still Image mode is the default capture mode.
- This setting is also available in Video mode.

## • Setup Menu

Setup menu can be accessed in both Still Image and Video modes.

1. Set the camera to Still Image mode.
2. Press the  ◀ button.
3. Press the ▲ or ▼ button to select  (SETUP).
4. Press the ► SET button.
5. Press the ▲ or ▼ button to select the desired setting.

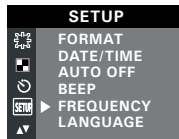

## • Formatting the Internal Memory

Formatting the internal memory deletes all data stored in it.

1. Set the camera to Still Image mode.
  2. Access the Setup menu.
  3. Press the ▲ or ▼ button to select “FORMAT”.
  4. Press the ►SET button.
- 
5. Press the ▲ or ▼ button to select the desired setting.
  6. Press the ►SET button.



### NOTE:

- Data deleted by a format operation cannot be recovered. Make sure you do not have any useful data currently stored in the internal memory before you format it.
- Formatting the internal memory destroys all the pictures, even those that are protected.
- With a memory card inserted, the above operation would format the inserted memory card only. The internal memory will not be formatted when a memory card is inserted.

## • Setting the Current Date and Time

1. Set the camera to Still Image mode.
2. Access the Setup menu.
3. Press the ▲ or ▼ button to select “DATE/TIME”.
4. Press the ►SET button.

### Setting the date format

5. Press the ▲ or ▼ button to select “DATE FORMAT”.
6. Press the ►SET button.
7. Press the ▲ or ▼ button to select the desired setting.
8. Press the ►SET button.

### Setting the date and time

5. Press the ▲ or ▼ button to select “SETUP”.
6. Press the ►SET button.
7. Press the ▲ or ▼ button to adjust the value in the field.
8. Press the **[M]** ◀ button to switch to the next field.
9. Press the ►SET button.

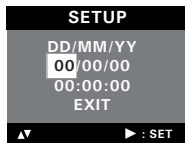
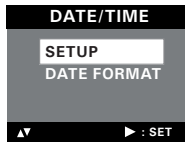
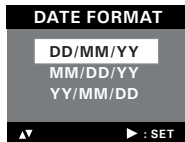
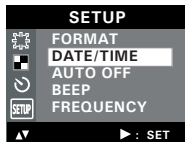

## • Auto Power Save Setting

The camera performs the following power save operations to conserve battery power.

**OFF** The power save feature is not activated.

**1/3/5 MIN** The camera is designed to switch off automatically to save battery life after the specified period of inactivity.

You can change the power save setting according to the following steps:

1. Set the camera to Still Image mode.
2. Access the Setup menu.
3. Press the ▲ or ▼ button to select "AUTO OFF".
4. Press the ►SET button.
5. Press the ▲ or ▼ button to select the desired setting.
6. Press the ►SET button.

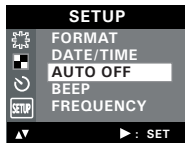

### NOTE:

- Auto power off is automatically disabled under any one of the following conditions.
  - While an auto play is undergoing.
  - While the camera's USB port is connected to a computer or other external devices, or while the camera is being controlled by an external device.
- The LCD screen automatically goes to hibernation after one minute of inactivity. Press any button, except the Power button, to re-activate the LCD screen.



## • Setting the Beep Sound On/Off

You can turn the beep sound on and off. When the beep sound is turned on, the camera will beep when you press the buttons.

1. Set the camera to Still Image mode.
  2. Access the Setup menu.
  3. Press the ▲ or ▼ button to select “BEEP”.
  4. Press the ►SET button.
- 
5. Press the ▲ or ▼ button to select the desired setting.
  6. Press the ►SET button.

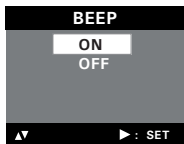
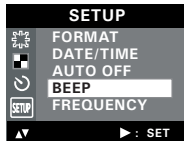

## • Setting Frequency

In order to take a better indoor picture, the camera needs to be set to suit the correct lighting frequency. Set the frequency to 60Hz for US and 50Hz for Europe.

1. Set the camera to Still Image mode.
  2. Access the Setup menu.
  3. Press the ▲ or ▼ button to select “FREQUENCY”.
  4. Press the ►SET button.
- 
5. Press the ▲ or ▼ button to select the desired setting.
  6. Press the ►SET button.

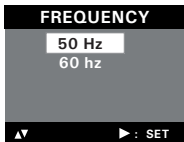
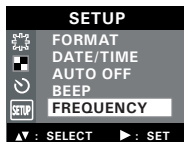

## • Setting Display Language

Under this setting, you can select the language you prefer for the LCD screen.

1. Set the camera to Still Image mode.
2. Access the Setup menu.
3. Press the ▲ or ▼ button to select “LANGUAGE”.
4. Press the ►SET button.

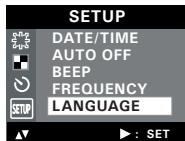

5. Press the ▲ or ▼ button to select the desired setting.
6. Press the ►SET button.



## • Setting the Date Stamp On and Off

Use the date stamp to imprint the date on your pictures.

1. Set the camera to Still Image mode.
2. Access the Setup menu.
3. Press the ▲ or ▼ button to select “DATE STAMP”.
4. Press the ►SET button.
5. Press the ▲ or ▼ button to select the desired setting.
6. Press the ►SET button.



### NOTE:

This setting is configured for images only.

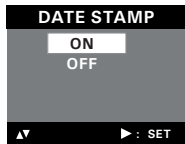
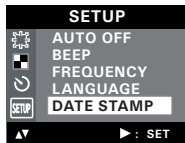

## • Resetting to Default Settings

You can easily change all the settings you made back to the camera default settings by the following steps.

Please refer to “Camera Default Settings” on page 80 for more details.

1. Set the camera to Still Image mode.
2. Access the Setup menu.
3. Press the ▲ or ▼ button to select “DEFAULT”.
4. Press the ►SET button.
5. Press the ▲ or ▼ button to select the desired setting.
6. Press the ►SET button.

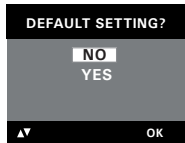
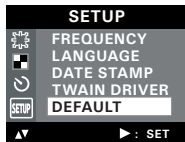

- **Switching the Information Display and LCD Screen On and Off**

Pressing the  button each time switches the LCD screen to the next display mode in the following sequence.

### Capture mode

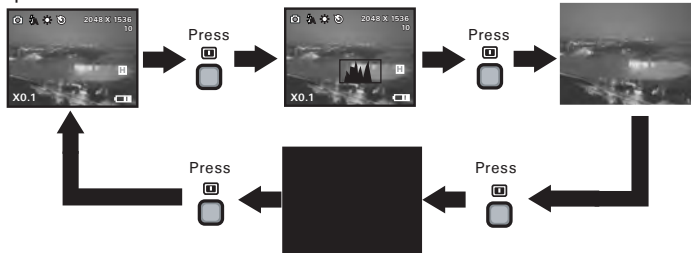

### Playback mode

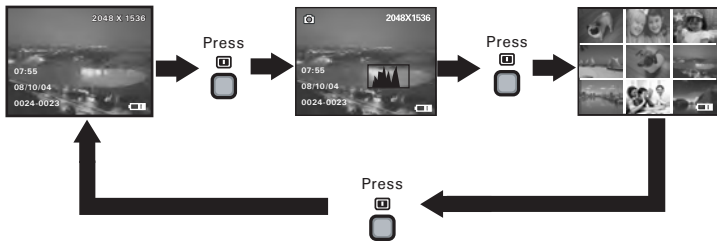

## 3 Taking Pictures

**Before you take pictures, please read this note first:**

### **Outdoor Pictures Without the Flash**

- Avoid intense sunlight that may cause sun spots in pictures.
- Always make sure that the sun or other light source is in front of the subject.

### **• Taking a Picture**

Taking pictures at approximately 3.2 feet to infinity (1 meter to infinity).

1. Set the camera to Still Image mode.
2. Frame your subject using the LCD screen or the viewfinder.
3. Hold the camera steady. Press the shutter button completely down to take a picture. A beep will sound (if the beep sound is turned on) when a picture is taken.

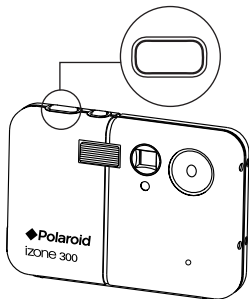

### **NOTE:**

Make sure that the Flash / Battery charge LED remains lighted before shooting.

### **• Taking a Picture with the LCD Screen Off**

You can also take a picture with the LCD screen off. The procedure is the same as above but frame your subject using the viewfinder instead.

### • Setting Flash Mode

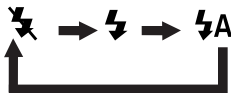

1. Set the camera to Still Image mode.
2. Pressing the Flash button cycles through the flash modes in the following sequence.



When you press the Flash button, the icon (according to the flash setting you selected) will appear on the LCD screen. You can now take pictures using the flash mode you have selected. The flash will recharge after each flashed picture.

The flash range is approximately 3.2 feet to 4.9 feet (1 to 1.5 meters).

The camera has three flash modes (default setting is Auto Flash). Use the flash when you take pictures at night, indoors, or outdoors in heavy shadows.

When shooting under these conditions:	Select this mode	Icon shown on the LCD screen
The flash does not fire. Use this setting for outdoor pictures, or where flash is prohibited or may be distracting, or when shooting towards a reflective surface, such as a window or a mirror. If there is not enough light when using this setting, your pictures may turn out dark.	Flash Off	
The flash fires automatically as needed. Use this setting to take most pictures.	Auto Flash	
The flash fires for every picture. Use this setting in high-contrast situations to provide fill-light or use it indoors in low light.	Forced On	





**NOTE:**

- Flash modes are not available in Video mode.
- Never touch or block the flash with your fingers. Doing so can soil these components and interfere with the correct flash operation.

## • Setting Self-timer

Your camera is designed with a self-timer function, which allows you to take pictures with a 10-second built-in timer.

1. Set the camera to Still Image mode.
2. Press the **(M)** ◀ button.
3. Press the ▲ or ▼ button to select  (SELF TIMER).
4. Press the ▶ **SET** button.
5. Press the ▲ or ▼ button to select the desired setting.
6. Press the ▶ **SET** button.
7. The icon  will appear on the LCD screen.



### NOTE:

To disable the self-timer function, repeat the above steps and select "OFF".



### NOTE:



Place the camera on a flat surface or use a tripod when using the self-timer function.





## • Zoom Feature

Your camera is designed with 3X digital zoom. This feature lets you zoom in on the central area of a photo and photograph only the enlarged portion of the picture.

1. Set the camera to Capture mode .
2. Press the  button to zoom in. Press the  button to zoom out. The zoom factor is shown on the LCD screen.

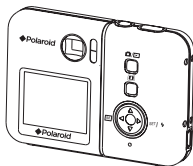

Digital Zoom Factor

For the digital zoom feature, the viewfinder does not reflect the actual zoomed image. We recommend the user to use the LCD screen to monitor the zoom factor.



### **NOTE:**

- You may notice a decrease in image quality when using the digital zoom.
- The zoom feature is not available during recording video clips at 320 x 240 pixels.

## • Setting the Image Size and Quality

Picture resolution refers to the number of pixels in a digital picture. Picture quality depends on the JPEG file compression that the camera applies when the picture is taken. Higher resolution and less compression produces better quality but occupies more memory space. Smaller size pictures and normal quality are easier to email while larger size and fine quality are better for printing.

### Image Size Setting

1. Set the camera to Still Image mode.
2. Press the **[M]** ◀ button.
3. Press the ▲ or ▼ button to select **[K] [L]** (IMAGE SIZE).
4. Press the ▶ SET button.
5. Press the ▲ or ▼ button to select the desired setting.
6. Press the ▶ SET button.

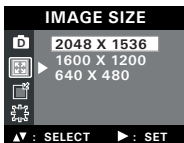
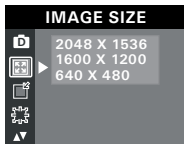

#### NOTE:

It is recommended to use the 2048 x 1536 resolution for printing.

## Quality Setting

1. Set the camera to Still Image mode.
2. Press the **[M]** ◀ button.
3. Press the ▲ or ▼ button to select **[QUALITY]**.
4. Press the ▶ **SET** button.
5. Press the ▲ or ▼ button to select the desired setting.
6. Press the ▶ **SET** button.

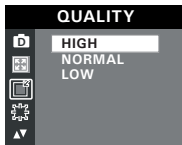

## • Setting Exposure Compensation

You can adjust the exposure compensation value (EV) within the range of -1.5EV to +1.5EV in order to compensate for current lighting conditions. This setting can be used to obtain better result when shooting with backlighting, indirect indoor lighting, a dark background, etc.

1. Set the camera to Still Image mode.
2. Press the **(M)** ◀ button.
3. Press the ▲ or ▼ button to select  (EXPOSURE).
4. Press the ▶ SET button.
5. Press the ▲ or ▼ button to select the desired setting.
6. Press the ▶ SET button.

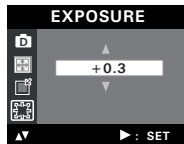
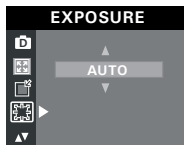

### NOTE:





- A higher EV value is best used for light-colored subjects and backlit subjects. A lower EV value is best for dark-colored subjects and for shooting outdoors on a clear day.
- When shooting under very dark or very bright conditions, you may not be able to obtain satisfactory results even after performing exposure compensation.

## • Setting the White Balance for Pictures

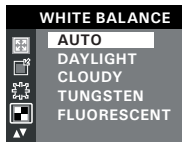
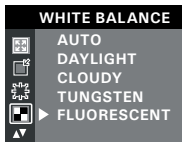
Selecting the right type of white balance can help to make the color of a subject in a picture appear more natural under the type of lighting that is available.

1. Set the camera to Still Image mode.
2. Press the **(M)** ◀ button.
3. Press the ▲ or ▼ button to select  (WHITE BALANCE).
4. Press the ▶ SET button.
5. Press the ▲ or ▼ button to select the desired setting.
6. Press the ▶ SET button.



When shooting under these conditions:	Select this setting
Automatic adjustment	
Outdoor daylight	
Cloudy	
Indoors, illuminated by tungsten lighting	
Indoors, illuminated by fluorescent lighting	

## 4 Recording Video Clips



### NOTE:

Change the drive mode from Still Image mode to Video mode before recording video clips, since Still Image mode is the default capture mode. Please refer to “Drive Mode” on page 21 for more details.

### • Recording Video Clips

Use the Video mode to record video clips. The recording time displayed on the LCD screen will decrease and the ● icon will blink while recording.

1. Set the camera to Video mode.
2. Frame your subject using the LCD screen.
3. Press the shutter button completely down to start recording.
4. Press the shutter button again to stop recording. Recording stops when the current memory is full.

Recording Indicator



## • Setting Video Resolution

Video resolution refers to the number of pixels in a digital video clip. Video clip quality depends on the file resolution that the camera applies when the video clip is recorded. Higher resolution makes better quality which occupies more memory space.

1. Set the camera to Video mode.
2. Press the **(M)** ◀ button.
3. Press the ▲ or ▼ button to select **IMAGE SIZE** (IMAGE SIZE).
4. Press the ▶ SET button.
5. Press the ▲ or ▼ button to select the desired setting.
6. Press the ▶ SET button.





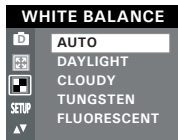
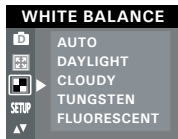

## • Setting the White Balance for Video Clips

Selecting the right type of white balance can help to make the color of a subject in the video clip appear more natural under the type of lighting that is available.

1. Set the camera to Video mode.
2. Press the **(M)** ◀ button.
3. Press the ▲ or ▼ button to select  (WHITE BALANCE).
4. Press the ▶ SET button.
5. Press the ▲ or ▼ button to select the desired setting.
6. Press the ▶ SET button.



When shooting under these conditions:	Select this setting
Automatic adjustment	
Outdoor daylight	
Cloudy	
Indoors, illuminated by tungsten lighting	
Indoors, illuminated by fluorescent lighting	



## 5 Reviewing and Managing Pictures and Video Clips



### NOTE:



Change the camera mode from Capture mode to Playback mode before reviewing pictures and video clips. Please refer to “Camera Mode” on page 21 for more details.

### • Reviewing the Pictures

1. Set the camera to Playback mode.
  2. Use the ▲ or ▼ button to view the pictures taken.
- The  icon is shown on the LCD screen when a picture is selected.

### • Reviewing Picture and Video Clip Files in Thumbnail

You can view up to 9 picture and video clip files at a time on the LCD screen by using the Thumbnail function.

1. Set the camera to Playback mode.
2. Press the  button twice. Thumbnail files will be shown on the LCD screen and the last reviewed picture will be highlighted.
3. Press the ▲, ▼,  ◀ and ▶ SET button to select a thumbnail file and view it in full screen by pressing the  button.

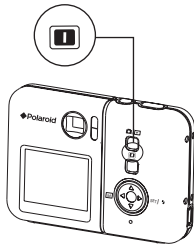

## • Auto Play

The Auto Play function enables you to view all the picture and video clip files stored in the camera one by one forward or backward on the LCD screen.

You can activate the Auto Play function and make Auto Play direction and interval according to the following steps.

1. Set the camera to Playback mode.
2. Press the **M** ◀ button.
3. Press the ▲ or ▼ button to select  (AUTO PLAY).
4. Press the ▶ SET button.
5. Press the ▲ or ▼ button to select "SETUP".
6. Press the ▶ SET button.



### Set Auto Play Direction

7. Press the ▲ or ▼ button to select "DIRECTION".
8. Press the ▶ SET button.
9. Press the ▲ or ▼ button to select the desired setting.
10. Press the ▶ SET button.



### Setting Auto Play Interval

7. Press the ▲ or ▼ button to select "INTERVAL".
  8. Press the ►SET button.
- 
9. Press the ▲ or ▼ button to select the desired setting.
  10. Press the ►SET button.

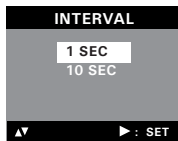

### Start Auto Play

Perform steps 1, 2, 3 and 4 on page 42.

5. Press the ▲ or ▼ button to select "ON".
6. Press the ►SET button.



The camera will automatically run from the last file that you have reviewed. Every file will display according to your interval setting. You may press the ▲ or ▼ button to stop the auto play. The auto play will keep running as long as there is power.

## • Playing the Video Clip

1. Set the camera to Playback mode.
2. Press the ▲ or ▼ button to select the video clip you want to play.
3. Press the ►SET button to start playing video clip. Press it again to pause.
4. Press the ▼ button to stop.



The  icon is shown on LCD screen when a video clip is selected.

## • Protect or Unprotect Picture(s) or Video Clip(s)

1. Set the camera to Playback mode.
2. Press the [M] ◀ button.
3. Press the ▲ or ▼ button to select  (PROTECT).
4. Press the ►SET button.
5. Press the ▲ or ▼ button to select the desired setting.
6. Press the ►SET button.





- |                    |  |
|--------------------|--|
| <b>LOCK THIS</b>   | Protect the selected picture or video clip                 |
| <b>UNLOCK THIS</b> | Remove protection from the selected picture or video clip  |
| <b>LOCK ALL</b>    | Protect all pictures and video clips in the current memory |
| <b>UNLOCK ALL</b>  | Remove protection from all of the pictures and video clips |













Once the images or video clips are protected, an  icon will appear on the LCD screen, indicating it is locked when you review it.



**NOTE:**

To protect one picture or video clip or to remove protection from one picture or video clip, use the  or  button to choose the selection you want to protect or unprotect before the above operation.



• **Deleting Picture(s) or Video Clip(s)**

1. Set the camera to Playback mode.
2. Press the   button.
3. Press the  or  button to select  (ERASE).
4. Press the  SET button.
  
5. Press the  or  button to select the desired setting.
6. Press the  SET button.
  
7. Press the  or  button to select the desired setting.
8. Press the  SET button.

You can cancel the deletion by choosing “NO”.



**NOTE:**

- To delete one picture or video clip, use the  or  button to select the one you want to delete before the above operation.
- Protected file can not be deleted. Remove protection before deleting.
- All deleted pictures and video clips can not be recovered.

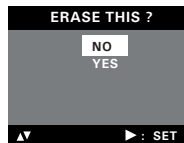

## 6 Print Settings

### • About PictBridge

PictBridge is a new industry standard that allows you to print images directly from a PictBridge enable digital still camera to a PictBridge compatible printer without using a photo editing software or a computer.

### Printing Procedures

1. Preparing the camera and the printer.

Camera	Be sure battery level is full before printing.
Printer	Refer to the user guide that comes with your printer and make preparations (paper, ink cassette, cartridge, etc.) as required.

Turn on the camera and the printer.

2. Selecting PictBridge mode

Set the camera to Playback mode and select the PictBridge mode. Refer to page 47 for details.

3. Connecting the camera to the printer

Refer to "Camera/Printer Connection" on page 48 for details.

4. Select print settings.

Use the camera's function and navigation buttons to select the print settings. Refer to page 49 for details.

5. Printing

Select "PRINT" and press the ► SET button to start printing. Refer to page 52 for details.

## Cancelling Printing

Press the ► SET button to cancel printing the print job. The printer will stop printing and eject the paper.

## Printing Errors

If for some reason an error occurs during or before printing, select “CANCEL” or “CONTINUE” and then press the ► SET button.



### NOTE:

- Please refer to the printer’s user guide for the solutions. Printing may resume once the problem is solved.
- Printing operation may still fail with some errors even if you press the ► SET button after selecting “CONTINUE”. In that case, select “CANCEL” and press the ► SET button.

## Selecting PictBridge Mode

1. Set the camera to Playback mode.
2. Press the **M** ◀ button.
3. Press the ▲ or ▼ button to select  (PRINT SETTING).
4. Press the ► SET button.
5. Press the ▲ or ▼ button to select “PICTBRIDGE”.
6. Press the ► SET button.



### NOTE:

To print a single image, select the image before enabling PictBridge mode.

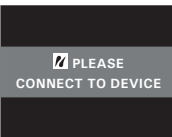
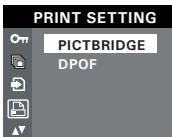
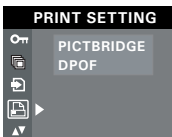
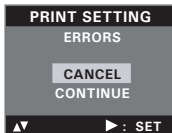
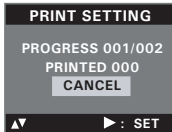

## Camera/Printer Connection

Connecting with the USB Cable.

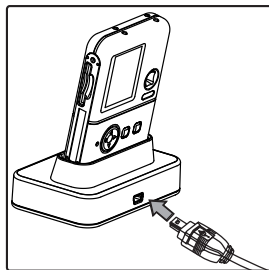
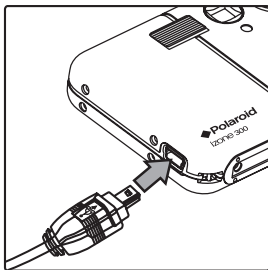

1. Plug Series A of the USB cable into the  marked socket on your printer. Location of USB socket will vary from printer to printer.
2. Plug Series Mini B of the USB cable into the port on your camera.



### NOTE:

- “ DEVICE IS CONNECTED” displays on the LCD screen, indicating a proper connection to the printer.
- Do not connect the USB cable to the camera until PictBridge is enable and when prompted by the “PLEASE CONNECT TO DEVICE” screen. Or if you already have connected the cable to the camera, do not plug into printer until prompt to do so. Not following this sequence will result in connection failure.
- When “PLEASE CONNECT TO DEVICE” is displayed for about ten seconds, it will skip to the PictBridge print setting screen even if there is no connection between camera and printer.





## Selecting Print Settings

1. Press the ▲ or ▼ button to select the print mode.



2. The following options are available.

THIS IMAGE	Print the selected image in the camera's internal memory or a memory card according to specified settings. Use the ▲ or ▼ button to designate the image you want to print before selecting the PictBridge mode.
ALL IMAGES	Print all images in the camera's internal memory or a memory card according to the specified settings.
ALL INDEX	All images in the camera's internal memory or a memory card are given an index and printed according to the specified settings.



### NOTE:

- To print a single image, select the image before enabling PictBridge.
- Print settings are configured for images only. Make sure there are no video clips or other file besides images in the memory before printing, otherwise, an error will occur if trying to print using the "ALL IMAGES" or "ALL INDEX" option.
- Not all printers will support all these print options. Please refer to the printer user guide for options available.

3. Press the **▶** SET button to select the print settings.

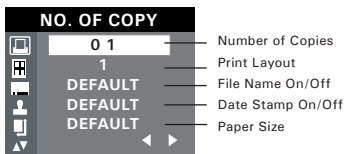

Select a setting item using the **▲** or **▼** button and select setting contents using the **(M)** **◀** or **▶** SET button.

**NOTE:**  
“**PRINTER SETTING NOT SUPPORTED**” may appear on the LCD screen after selecting a particular setting. The camera’s print settings are not supported by the printer. In this case, select “**DEFAULT**” for this particular setting, or visit <http://www.polaroid.com> for possible solutions.

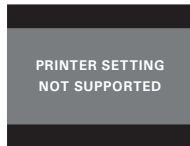



### Specifying the Number of Copies

1. Press the **▲** or **▼** button to select  (NO. OF COPY).
2. Press the **(M)** **◀** or **▶** SET button to specify the number of copies (from 1 to 99) you want to print for the selected image or all images.

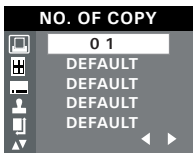
**NOTE:**  
“01” is the default setting.



## Selecting Print Layout

1. Press the ▲ or ▼ button to select  (N-UP LAYOUT).
2. Press the  ◀ or ▶ SET button to specify the number of printed images on a page.

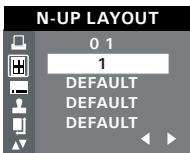

DEFAULT Print settings differ according to the printer model.

1/2/4/6/8 Print 1/2/4/6/8 on a page.

BORDERLESS Print right to the edge of the page.

## Setting the File Name On/Off

1. Press the ▲ or ▼ button to select (FILE NAME).
2. Press the  ◀ or ▶ SET button to select "DEFAULT", "ON" or "OFF".

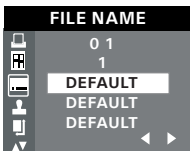

DEFAULT Print settings differ according to the printer model.

ON Add the file name to the printed image.

OFF Print without the file name.

## Setting the Date Stamp On/Off

1. Press the UP or DOWN button to select (DATE STAMPING).
2. Press the  ◀ or ▶ SET button to select "DEFAULT", "ON" or "OFF".

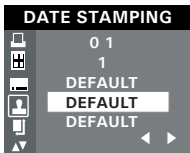



DEFAULT Print settings differ according to the printer model.

ON Add the date stamp to the printed image.

OFF Print without the date stamp.

## Selecting Paper Size

1. Press the ▲ or ▼ button to select  "SIZE".
2. Press the  ◀ or ▶ SET button to select the paper size.

The following paper sizes are available:  
8" x 10", 4" x 6", A4 and default.

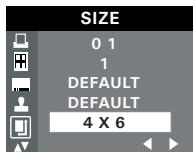

DEFAULT Print settings differ according to the printer model.

## Printing

1. Press the ▲ or ▼ button to select "PRNIT".
2. Press the ▶ SET button.



### NOTE:

To return to the normal playback mode, press the ▲ or ▼ button to select "EXIT" and press the ▶ SET button.

## • DPOF (Digital Print Order Format)

“DPOF” stands for “Digital Print Order Format”, which is a format for recording on a memory card or other medium which captured images and how many copies should be printed. Then you can print on a DPOF-compatible printer or at a professional print service from the memory card in accordance with the file name and number of copies settings recorded on the card.

With this camera, you should always select images by viewing them on the LCD screen. Do not specify images by file name without viewing the file contents.



### NOTE:

Print settings are configured for images only. Make sure there are no video clips or other file besides images in the memory before printing, otherwise, an error will occur if trying to print using the “ALL IMAGES” option.

1. Insert an SD card into the camera.
2. Turn on the camera.
3. Set the camera to Playback mode.
4. Press the **[M]** ◀ button.
5. Press the ▲ or ▼ button to select  (PRINT SETTING).
6. Press the ▶ SET button.
7. Press the ▲ or ▼ button to select “DPOF”.
8. Press the ▶ SET button.

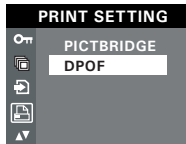
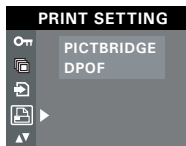

9. Press the ▲ or ▼ button to select the desired setting.
10. Press the ► SET button.



- THIS IMAGE** The selected picture in a memory card will be printed up to 99 copies.
- ALL IMAGES** All pictures in a memory card will be printed up to 99 copies for each picture.



**NOTE:**

To print a single image, select the image before enabling DPOF mode.

11. Press the ▲ or ▼ button to select the desired setting.
12. Press the ► SET button.



13. Remove the memory card from the camera and insert it into the printer's card slot (as illustrated). Location of the card slot may vary from printer to printer model.



**NOTE:**

Make sure you turn off the camera before inserting or removing a memory card.

14. Press the Print button on the printer to start printing.

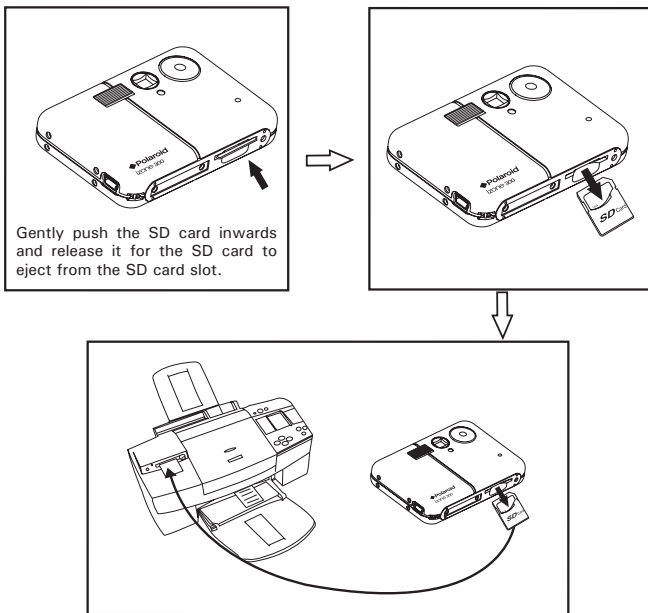

## 7 Using the SD (Secure Digital) Card

### • Using the SD Card

Your camera comes with built-in flash memory for storing pictures and video clips. You can expand the memory using a commercially available SD card (up to 1GB). The camera senses whether a memory card is inserted, and automatically saves pictures and video clips accordingly. Note that you cannot save pictures or video clips to the built-in flash memory while a memory card is installed in the camera.

See pages 76 to 78 for storage capacities.

### Memory Card Precautions

1. Use only an SD memory card with this camera.
2. Electrostatic charge, electrical noise, and other phenomena can cause data corruption or even loss. Always make sure that you always back up important data on other media (MO disc, computer hard drive, etc.).
3. If a memory card starts to behave abnormally, you can restore normal operation by reformatting it. However, we recommend that you always take along more than one memory card whenever using the camera far away from the home or office.
4. We recommend that you format a memory card before using it for the first time after purchasing it, or whenever the card you are using seems to be the cause of abnormal pictures. Remember to format a memory card if it was used in another digital camera or other devices.





## IMPORTANT!

- Make sure you turn off the camera before inserting or removing a memory card.
- Be sure to orient the card correctly when inserting it. Never try to force a memory card into the slot when you feel resistance.
- SD memory cards have a write protection switch that you can use to protect files from accidental deletion. However, you must remove the write protection whenever you want to record new files onto it, format it, or delete its files.
- Files contained in the SD card recorded by other cameras may conflict with the izone300™ camera, and valuable data in your existing SD card may be distorted or lost when the card is inserted in the izone300™ camera. We strongly recommend the user to use a NEW or formatted SD card for the izone300™ camera. The manufacturer is not liable for losing or corrupting any valuable data or files in your SD card due to your improper operation.
- As tests prove, the izone300™ works best with popular brands of memory cards such as SanDisk, Panasonic, Lexar and TOSHIBA. Consider using these cards for best performance.

### Inserting the SD Card

Turn off the camera. Insert the SD card and ensure the card is inserted correctly as illustrated.

The  icon will appear on the LCD screen when a SD card is inserted into the camera.

### Removing the SD Card

To remove the SD card, turn off your camera and gently push the SD card inwards. And then release it for the SD card to eject from the SD card slot.

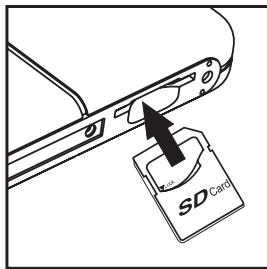



### **IMPORTANT!**

- Never insert any other object into the camera's SD card slot. Doing so creates the risk of damage to the camera and card.
- Should water or any foreign objects ever get into the card slot, immediately turn off the camera, remove the batteries and contact your dealer or nearest service provider.
- Never remove a card from the camera while the camera is powered on. Doing so can cause the recording operation to fail, and even damage the memory card.

### **Formatting the SD Card**

Formatting the SD card erases all files stored in it, including the protected ones. Removing the SD card during formatting may damage the card.

1. Insert an SD card into the camera card slot.
2. Turn on the camera.
3. Procedures are the same as for formatting the internal memory. Refer to "Formatting the Internal Memory" on page 22 for details.



### **IMPORTANT!**

- You can format a memory card on the camera or on a computer. However formatting a memory card on a computer takes much longer.
- Note that the data deleted by a format operation cannot be recovered. Make sure you do not have any useful data currently stored on a memory card before you format it.

## • To Copy Pictures and Video Clips from Internal Memory to a Memory Card

1. Insert an SD card into the camera card slot.
2. Turn on the camera.
3. Set the camera to Playback mode.
4. Press the **(M)** ◀ button.
5. Press the ▲ or ▼ button to select  (COPY TO CARD).
6. Press the ▶ SET button.
7. Press the ▲ or ▼ button to select the desired setting.
8. Press the ▶ SET button.

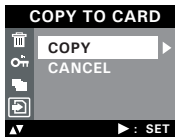

In the above operation, you can exit to the normal Playback mode by choosing “CANCEL” and confirm it. Please note that you cannot copy pictures or video clips from a memory card to the internal memory.



### NOTE:

The original pictures and video clips will still be in the camera’s internal memory after the copy operation has been performed. You must take the card out before you can erase it.

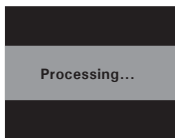

## 8 Installing the Software onto a Computer

### • Installing the Software

*For Windows® Users:*

PC



#### **IMPORTANT!**

- Please backup all the necessary data before any driver and software installation.
- The CD-ROM is tested and recommended to use under English Windows OS.
- Please restart the computer after installing the software.



#### **IMPORTANT! (For Windows® 98SE)**

Windows® 98SE needs to install the izone300™ camera driver for Mass Storage function. After the installation, please restart the Windows before connecting the camera to the PC.



#### **IMPORTANT!**

To experience higher performance in graphics and sound when you're watching video clips on your PC, it is recommended to install the DirectX ver. 9.0 or above. It can be downloaded from <http://www.microsoft.com/directx>.



#### **IMPORTANT! (For Windows® Me, 2000, XP)**

Directly plug-in the camera to transfer and view the pictures. No need to install the driver.



**IMPORTANT!**-If the computer requests you to install the Windows® system disk during the software installation, place the Windows® CD into the computer CDROM drive or insert the izone300™ driver CD to the CD-ROM drive. If izone300™ driver CD is inserted, please set the path to "CD-ROM drive \software\Driver\Sysfile". The computer will install the necessary files from the CD automatically. When the software completes installation, close the Windows® screen. Remove the Windows® CD and store safely.

1. Before you begin, close all other software applications opened on your computer.
2. Insert the CD supplied into the computer CD-ROM Drive.
3. The CD User Interface Screen will automatically launch.
4. With the mouse, click on each software interface button in turn and follow the on-screen instructions.

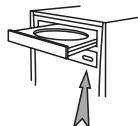

**NOTE:**

If the setup screen does not appear after loading the CD, then you can manually start it by double clicking the "My Computer" icon on your desktop, then double clicking the icon for the CD-ROM drive. When the CD-ROM window opens, double click the "INSTALL-E.EXE" icon.

**Mac**

***For Macintosh Users:***

1. Before you begin, close all other software applications opened on your computer.
2. Insert the CD supplied into the computer CD-ROM Drive.
3. Double click the CD-ROM icon "Polaroid".
4. Install the software included.

- **Software Included with Your Camera**

**izone300™ Camera Driver *Plug & Play removable disk***

Easy to use, just plug the camera to a computer and use it as a removable disk. Use the izone PhotoBase to edit and print the Pictures.

**izone PhotoBase *software* - the intelligent software that makes finding your pictures easy!**

izone PhotoBase helps you to organize and present multimedia files. You can quickly and easily create Slide Shows, Web Albums and Video Postcards. Meanwhile, you can effectively print contact sheets for quick image referencing. The unique “album” structure of the program makes file access convenient. On top of that, you can acquire files from various sources, including digital cameras, scanners, video devices, and removable media.

After you plug-in the camera, the izone PhotoBase software automatically checks to see if you have taken new photos that need to be transferred to your computer. If there are new images, you will be prompted if you want izone PhotoBase to download all the images in the camera to your computer automatically.

With the izone PhotoBase software, you can quickly sort all the photos on your computer either by the date or by image/folder name. Once you have located your images, you can make your simple edits, print or share in no time at all!

**Microsoft® NetMeeting™ Web Cam software**

NetMeeting™ provides the most complete conferencing solution for the Internet and corporate intranet.

Powerful features let you communicate with both audio and video, collaborate on virtually any Windows-based application, exchange graphics on an electronic whiteboard, transfer files, use the text-based chat program, and much more. Using your PC and the Internet, you can now hold face-to-face conversations with friends and family around the world.

**Adobe® Acrobat® Reader™ .PDF File Reading Software**

Adobe® Acrobat® Reader™ lets you view and print Adobe Portable Document format (PDF) files on all major computer platforms, as well as fill in and submit Adobe PDF forms online.

## • Computer System Requirements

For acceptable picture transferring and editing performance, we recommend the following minimum requirements;

**PC**

### *For Windows® Users*

---

- Compatible with Microsoft® Windows® 98SE, Me, 2000 or XP
- Pentium® III 450MHz or equivalent processor
- 128MB RAM (512MB recommended)
- USB Port
- DirectX 9.0 or higher
- 500MB free disk space
- Color monitor with high color (16-bit) graphic capability or higher
- CD-ROM drive
- Standard mouse and keyboard
- Stereo speakers

**Mac**

### *For Macintosh Users*

---

- PowerPC® Processor
- Mac™ OS Version 9.2~X
- USB Port
- 96MB RAM (128MB recommended)
- 400MB Free disk space
- Color monitor with high color (16-bit) graphic capability or higher
- CD-ROM drive
- Standard mouse and keyboard
- Stereo speakers



## 9 Transferring Pictures and Video Clips to Your Computer

### • Before You Transfer Files



#### IMPORTANT!

**BEFORE YOU CONNECT YOUR DIGITAL CAMERA TO THE COMPUTER, MAKE SURE THAT YOU HAVE INSTALLED THE SOFTWARE FROM THE ENCLOSED CD. PLEASE REFER TO "8 Installing the Software Onto a Computer".**

### • Changing the Driver Type Between Mass Storage Mode and PC Camera Mode

You can choose either Mass Storage or PC Camera as a driver type in this camera. Mass storage is the drive type by default. Set the camera to the PC Camera mode when you want to use the PC Camera function.

Mass Storage mode allows the camera to become an external hard disk drive, and you may view and download pictures and video clips stored in your camera's internal memory or a SD memory card onto your computer. PC Camera mode allows you to take video clips on your computer.

1. Set the camera to Still Image mode.
2. Access the Setup menu.
3. Press the ▲ or ▼ button to select "TWAIN DRIVER".
4. Press the ►SET button.
5. Press the ▲ or ▼ button to select the desired setting.
6. Press the ►SET button.



#### NOTE:

The driver type always resets to Mass Storage when the camera is turned off.

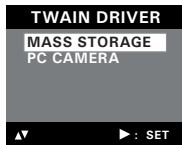
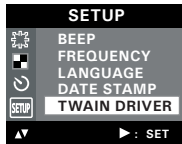

*For Windows® and Macintosh Users:*

## • Connecting to Your Computer

Connecting with the USB Cable.

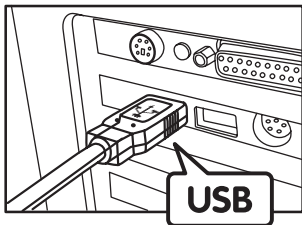

USB Series "A" Plug connects to your PC

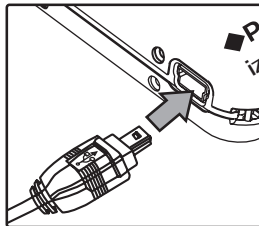

USB Series "Mini B" Plug connects to your izone300™ Camera or Docking Station

1. Turn off the camera.
2. Plug Series A of the USB cable into the  marked socket on your computer.
3. Plug Series Mini B of the USB cable into the port on your camera or on the docking station.
4. Turn on the camera and an interface "New Hardware Found" will show on the computer desktop.
5. A removable disk drive will be installed onto your computer automatically.

## • Transferring Pictures and Video Clips

PC

### *For Windows® Users:*



**NOTE:**

You can transfer pictures and video clips in any mode.

1. Turn on the camera
2. Connect the camera to a computer via the USB cable.
3. Double click on “My Computer” on your PC desktop and you will see a “Removable Disk” drive.
4. Double click “Removable Disk” -> double click “DCIM”-> double click any directory folder under “DCIM”.
5. All the pictures and video clips are in the directory folder. Highlight the pictures and video clips and drag them to a folder of your choice. You can also create sub-folders to group them or use the PhotoBase software to edit and manage the pictures or video clips.

### *For Macintosh Users*

Mac



**NOTE:**

For Mac user, directly plug-in the camera and no need to install the driver.

1. Turn on the camera
2. Set the camera to Playback mode.
3. Connect the camera to a computer via the USB cable, the systems will automatically recognize the MASS STORAGE drive. (System will automatically create a Mass Storage named “Unlabelled”)



**NOTE:**

This Drive name will vary from different version of Mac OS system.

4. Double click the folder “Unlabelled” to enter sub-folder “DCIM”.
5. Double click the folder “DCIM” and then any sub folder inside.
6. You can copy the pictures and video clips from this directory folder and paste to the hard disk.

## 10 Using the Camera as a Web Cam



### **IMPORTANT!**



Before using the Web Camera function, make sure that your camera has been switched to PC Camera mode. (Please refer to “Changing the Driver Type Between Mass Storage Mode and PC Camera Mode” on page 64 for more details.

### • **Setting up NetMeeting™**



#### **NOTE:**

Set the camera to Video Mode before starting NetMeeting™.

1. Place the camera into the docking station. For further details, refer to “Using the Docking Station” on page 9.
2. Plug the labelled end  of the USB cable into the socket marked  on your computer. Plug the other end of the USB cable into the USB port on the docking station.
3. When it is the first time to use the camera as a “Web Cam”. The Windows may prompt the user to insert the Windows system disk. Please insert the izeone300™ driver CD or the Windows CD into the CD-ROM drive to install the requested files.
4. Connect your microphone (not included) and speakers (not included) to your audio card’s Mic in and line out jack respectively.

## • Start NetMeeting™



### NOTE:

For Windows® XP / 2000 users who use NetMeeting for the first time , go to Start -> Run -> type in "conf" ->click "OK" and then follow the on-screen set up instruction to set up NetMeeting.

1. Double click the "NetMeeting" icon on the desktop or select the "NetMeeting" icon from the Windows Start Menu.
2. If you need further help on how to use Microsoft® NetMeeting™, select the "Help" under the menu bar and choose the topic you need. You can also refer to Polaroid "EASY TO USE GUIDE TO MICROSOFT® NETMEETING™" or visit the website:  
<http://www.microsoft.com/windows/netmeeting>.

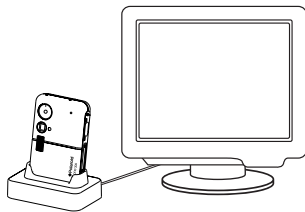

## 11 Troubleshooting Problems

The troubleshooting guide is designed to help you. If problems continue, please contact customer support. Details are provided under “Getting Help”.

Symptom	Problem	Solution
I receive an error message when I am installing the Polaroid izone300™ camera driver.	Polaroid izone300™ camera driver” does not load.	Shut down all other applications and attempt to reinstall the driver.
		Check to see if the USB controller in your BIOS if it is activated. Please refer to Polaroid website for how to activate USB controller in BIOS.
I cannot upload images to my computer.	Connection failure.	Check all cable connections are secured.
	Incorrect driver type.	Set the camera’s driver type to the Mass Storage mode.
I cannot run the Polaroid izone300™ camera driver”.	Conflict with another camera driver or capture device.	If you have another camera installed on your computer, remove it and it’s driver completely from your system to avoid conflicting with your izone300™.
My CD Installation wizard does not work.	The auto installation file is switched off or the CD-ROM is disconnected.	Go to the computer desktop. Right click on “My Computer”. Click “Properties”. Select “Device Manager”. Double click on “CD-ROM”, double click on “CD-R (normally the manufacturer’s name. Click on “Settings”. Ensure both “Auto insert notification” and the “disconnect” are ticked. If you change the settings the computer will ask you to restart your PC. Click “Yes”.
I get a blurred image when uploading my images to my computer.	There may be a momentary delay between pressing the shutter button and the actual exposure.	Hold your izone300™ camera steady until you hear a beep which indicates the exposure is completed.

Symptom	Problem	Solution
My izone300™ camera hanged and all buttons do not work.	Your camera may be affected by the electrostatic discharge.	Depress the Reset button gently (holding for about 5 seconds) using a paper clip or ball pen.
I cannot activate my digital camera by pressing the Power button.	Battery is exhausted.	Recharge the battery.
Camera suddenly powers off.	Auto power off function is activated. Or Battery is exhausted.	Turn the camera on. Or Recharge the battery.
Image is not recorded when the shutter button is pressed.	Camera is turned off Or Flash unit is charging. Or Memory is full.	Turn the camera on. Or Wait until flash unit charging finishes. Or Delete images you no longer need, or use another memory card.
Camera powers off during self-timer countdown.	Battery is exhausted.	Recharge the battery.
Recorded pictures are not saved in memory.	Camera powers off before the save operation is complete. Or Removing the memory card before the save operation is complete.	If the battery indicator is on the LCD screen, replace batteries with a full set of new ones as soon as possible. Or Do not remove the memory card before the save operation is complete.
Color of the playback pictures is different from the picture on the LCD screen during recording.	Sunlight or light from another source is shining directly into the lens during recording.	Position the camera so that sunlight does not shine directly onto the lens.
Pictures are not displayed.	A memory card with non-DCF pictures recorded with another camera is loaded in the camera.	This camera cannot display non-DCF pictures recorded onto a memory card used by another digital camera.
My memory card is not recognized by the camera when it is inserted into the card slot.	Some brands of memory cards may not have their physical dimensions meeting the international standard. As a consequence, these cards will not be recognized by your camera.	Try another brand of memory card with your camera. If problem still exist, please visit <a href="http://www.polaroid.com">http://www.polaroid.com</a> for customer service.

Symptom	Problem	Solution
I cannot erase pictures.	All the pictures in memory are protected.	Unprotected the pictures you want to delete.
AVI file cannot be played.	DirectX version is lower than 9.0. Or Windows Media player not installed in the computer	Install directx 9.0 or above. Visit <a href="http://www.microsoft.com/directx">http://www.microsoft.com/directx</a> for more detail. Or Please go to <a href="http://www.microsoft.com/windows/windowsmedia/players.aspx">http://www.microsoft.com/windows/windowsmedia/players.aspx</a> to download the Windows Media Player to play the video clips.
The camera is detected by the Windows and works properly. But a drive letter of the Removable disk is not created.	The removable disk crashes with the network drives.	Disconnect the crashed network drive and reserve this drive letter for the camera.
There is no response from the camera while pressing any buttons.	The LCD screen is frozen or the camera is hanged.	Depress the Reset button gently (holding for about 5 seconds) using a paper clip or ball pen.
An error message appears on the LCD screen before or during printing.	Printer may not support some advanced print features. Or Some fault occurs with the printer. Or Print settings can be configured for images only.	Select "DEFAULT" for a particular print setting or visit <a href="http://www.polaroid.com">http://www.polaroid.com</a> for the solutions. Or Please refer to the printer's user guide for the solutions. Or Make it sure that there is no video clips or other file format in the current memory before printing.
Pictures are overexposed or under exposed.	An incorrect flash mode is applied for shooting.	Select a correct flash mode for shooting according to the surrounding lighting conditions.
When connect the camera to the PC in Capture mode, Windows prompt to insert system disk.	izone300™ camera driver installation has not completed.	Insert the Windows CD or izone300™ driver CD. If izone300™ driver CD is inserted, please set the path to CD-Rom drive\software\Driver\Sysfile . And continue the installation.

**Please also refer to the help files & User Guides that accompany the enclosed applications. For further information and support, please visit our website: <http://www.polaroid.com>**



## 12 Getting Help

- **Polaroid Online Services**

Website: <http://www.polaroid.com>

- **Customer Support**



Questions? Need Help? Call us at 0120-103-772. Or visit us at <http://www.polaroid.com>

- **ArcSoft Software Help**

**For United States**

ArcSoft HQ Support Center

(Fremont, CA 94538)

Tel.: 1-510-979-5599

Fax: 1-510-440-7978

E-mail: [support@arcsoftsupport.com](mailto:support@arcsoftsupport.com)

Web: <http://www.arcsoft.com/en/support/>

**For Latin America**

E-mail: [latinsupport@arcsoftsupport.com](mailto:latinsupport@arcsoftsupport.com)

**For Europe**

ArcSoft Europe Support Center

(Ireland)

Tel.: +353-(0) 61-702087

Fax: +353-(0) 61-702001

E-mail: [eurosupport@arcsoft.com](mailto:eurosupport@arcsoft.com)

**For China**

ArcSoft China Support Center

(Hangzhou)

Tel.: +86-571-88210575

E-mail: [support@arcsoft.com.cn](mailto:support@arcsoft.com.cn)

Web: <http://www.arcsoft.com.cn/new/support>

**For Japan**

ArcSoft Japan Support Center (Tokyo)

Tel.: +81-3-5795-1392

Fax: +81-3-5795-1397

E-mail: [support@arcsoft.jp](mailto:support@arcsoft.jp)

Web: <http://www.arcsoft.jp>

**For Taiwan**

ArcSoft Taiwan Support Center (Taiwan)

Tel.: +886-(0) 2-2506-9355

Fax: +886-(0) 2-2506-8922

E-mail: [support@arcsoft.com.tw](mailto:support@arcsoft.com.tw)

Web: [www.arcsoft.com.tw](http://www.arcsoft.com.tw)

Visit <http://www.arcsoft.com> for technical support and frequently asked questions (FAQ's).

“Polaroid” and “Polaroid and Pixel” and “izone” are trademarks of Polaroid Corporation, Waltham, MA, USA.

## 13 Appendix

### • Technical Specifications

Picture Resolution	<ul style="list-style-type: none"><li>• Sensor:<ul style="list-style-type: none"><li>- 1/2.5 inch</li><li>- 3.2 Mega Pixels CMOS</li></ul></li></ul>
Lens	<ul style="list-style-type: none"><li>• Type: 5 elements plus IR filter</li><li>• Aperture: F 3.5</li><li>• Focal Length: 8.66 mm</li><li>• Focal Distance<ul style="list-style-type: none"><li>- Normal Focus: 3.2 ft to <math>\infty</math> (1 m to <math>\infty</math>) (The focusing range is the distance from the lens surface to the subject.)</li></ul></li><li>• Focus Zones: center</li></ul>
LCD Screen	1.5" TFT color panel
Built-in Flash	<ul style="list-style-type: none"><li>• Modes<ul style="list-style-type: none"><li>- Auto Flash, Forced On, Flash Off</li></ul></li><li>• Range: 3.2 to 4.9 ft (1 to 1.5 m)</li></ul>
Exposure Control	-/+1.5 EV in 0.3 increments
Shutter Speed	Electronic shutter 1/1000 sec ~ 1/20 sec
White Balance	Auto, Daylight, Cloudy, Tungsten, Fluorescent

Storage	<ul style="list-style-type: none"> <li>• Internal Memory: 8MB (3MB for data storage) or 16MB (11MB for data storage) Nand Flash</li> <li>• External Memory <ul style="list-style-type: none"> <li>- supports SD card up to 1GB (not included)</li> </ul> </li> </ul>
File Format	<ul style="list-style-type: none"> <li>• Still Image <ul style="list-style-type: none"> <li>- EXIF 2.2 compatible format (JPEG compression)</li> </ul> </li> <li>• Video Clip: AVI format</li> </ul>
Power Supply	One lithium ion rechargeable battery (integrated)
Self-timer	10 seconds with beep sound
Connectivity	With computer via USB cable and docking station (included)
Dimension	<ul style="list-style-type: none"> <li>• Size: (W) 91 mm x (D) 17 mm x (H) 63.5 mm</li> <li>• Weight: Approximately 90g (including the integrated battery and excluding card)</li> </ul>
Operating System	<ul style="list-style-type: none"> <li>• For Windows® Users: Microsoft® Windows® 98SE, Me, 2000 or XP</li> <li>• For Macintosh Users: Mac OS 9.2~X</li> </ul>

## • Storage Capacities

The charts below indicate the approximate numbers of pictures and length of video clips the camera can hold at each setting based on the internal memory and different capacities of SD card.

### Recordable Images

Units: Images

Resolution	Quality	8MB Internal Memory (3MB for data storage)	16MB Internal Memory (11MB for data storage)	32MB SD	64MB SD
2048 x 1536	High	3	18	35	70
	Normal	6	28	54	108
	Low	9	28	55	110
1600 x 1200	High	7	31	62	124
	Normal	12	45	90	180
	Low	17	48	96	192
640 x 480	High	31	127	234	468
	Normal	46	145	290	580
	Low	62	149	298	596

Resolution	Quality	128MB SD	256MB SD	512MB SD	1GB SD
2048 x 1536	High	140	280	560	1120
	Normal	216	432	864	1728
	Low	220	440	880	1760
1600 x 1200	High	248	496	992	1984
	Normal	360	720	1440	2880
	Low	384	768	1536	3072
640 x 480	High	936	1872	3744	7488
	Normal	1160	2320	4640	9280
	Low	1192	2384	4768	9536

## Recordable Video Length

Units: Minute

	Resolution	Video clips can be taken
8MB Internal Memory (3MB for data storage)	640 x 480	0.2
	320 x 240	0.3
16MB Internal Memory (11MB for data storage)	640 x 480	1.4
	320 x 240	1.5
32MB SD	640 x 480	2.6
	320 x 240	2.9
64MB SD	640 x 480	5.1
	320 x 240	5.1
128MB SD	640 x 480	9.6
	320 x 240	10
256MB SD	640 x 480	19.2
	320 x 240	20.6
512MB SD	640 x 480	37.7
	320 x 240	40.1
1GB SD	640 x 480	75.6
	320 x 240	81.1



### NOTE:

Scene complexity affects a picture's file size. For example, a picture of trees in autumn has a larger file size than a picture of blue sky at the same resolution and quality setting. Therefore, the number of pictures you can store on a memory card may vary.

## • Uninstalling Polaroid izeone300™ driver (PC Only)

PC

*For Windows® 98SE Users:*



### NOTE:

The following driver uninstall procedure is for Windows 98SE users only because only Windows 98SE needs to install the izeone300™ driver.

1. Open Add/Remove Program Properties in Control Panel and select "Polaroid Digital Cam" program, then click Add/Remove .
2. The following dialog box appears, click "OK" to confirm removing the camera driver.
3. The uninstallation program runs automatically, please restart your computer when it is finished.



## • Camera Default Settings

Camera Mode	Description	Default
Still Image Mode	Image Resolution	2048 x 1536
	Quality	High
	Exposure Compensation	Auto
	White Balance for Pictures	Auto
	Flash Mode	Auto Flash
Video Mode	Video Resolution	640 x 480
	White Balance	Auto
Setup Mode	Date Format	DD/MM/YY
	Auto Power Off	1 minute
	Beep	On
	Frequency	60 Hz for USA/ 50 Hz for Europe
	Language	English
	Date Stamp	Off
	Twain Driver	Mass Storage



### **NOTE:**

The default language for the LCD screen may vary with different countries and regions.



## • Using Your Battery

### Limit the following activities that reduces battery life:

- Reviewing your pictures on the LCD screen.
- Using the LCD screen to take pictures (Use the optical viewfinder to frame pictures).
- Excessive use of the flash.

### WARNINGS!

- Battery should be recharged by an adult.
- Batteries life varies depends on the camera usage.

These instructions should be retained for future reference.

## • Tips, Your Safety & Maintenance

Your Camera should only be operated within the following environmental conditions;

- 32 - 104° Fahrenheit; 0 - 40° Celsius
- 20% - 85% relative humidity, non condensing

Battery life or image quality may be affected outside these conditions.



### Camera Cautions

- NEVER immerse any part of the Camera or its accessories into any fluid or liquid.
- ALWAYS disconnect the Camera from your PC or TV before cleaning it.
- ALWAYS remove dust or stains with a soft cloth dampened with water or neutral detergent.
- NEVER place hot items on the surface of the Camera.
- NEVER attempt to open or disassemble Camera as this will affect any warranty claim.

## • Regulatory Information

### FCC Notice

This device complies with Part 15 of FCC Rules. Operation is subject to the following two conditions: (1) This device may not cause harmful interference, and (2) This device must accept any interference received, including interference that may cause undesired operation.

Warning: Changes or modifications to this unit not expressly approved by the party responsible for compliance could void the user's authority to operate the equipment.

NOTE: This equipment has been tested and found to comply with the limits for Class B digital device, pursuant to Part 15 of the FCC Rules. These limits are designed to provide reasonable protection against harmful interference in a residential installation. This equipment generates, uses and can radiate radio frequency energy and, if not installed and used in accordance with the instructions, may cause harmful interference to radio communications.

However, there is no guarantee that interference will not occur in a particular installation. If this equipment does cause harmful interference to radio or television reception, which can be determined by turning the equipment off and on, the user is encouraged to try to correct the interference by one or more of the following measures:

- Reorient or relocate the receiving antenna.
- Increase the separation between the equipment and receiver.
- Connect the equipment into an outlet on a circuit different from that to which the receiver is needed.
- Consult the dealer or an experienced radio/TV technician for help.

Shielded cable must be used with this unit to ensure compliance with the Class B FCC limits.

Under the environment with electrostatic discharge, the product may malfunction and require user to reset the product.

US 1105  
Part No.: OM3392US008